



## 6C Models - for Lightning Fast Production of Parts in One-Operation.

### Single Turret Series

<b>1 3/4"</b> Models:	<b>B545</b> main spindle, tailstock, 1-turret	<b>B545S</b> main spindle, sub-spindle, 1-turret	<b>B545L</b> main spindle, tailstock, 1-turret with live tools	<b>B545SL</b> main spindle, sub-spindle, 1-turret with live tools	<b>B545LY</b> main spindle, tailstock, Y-axis turret with live tools	<b>B545SLY</b> main spindle, sub-spindle, Y-axis turret with live tools	
	<b>2 5/8"</b> Models:	<b>735E</b> main spindle, tailstock, 1-turret	<b>735SE</b> main spindle, sub-spindle, 1-turret	<b>735LE</b> main spindle, tailstock, 1-turret with live tools	<b>735SLE</b> main spindle, sub-spindle, 1-turret with live tools	<b>735LY</b> main spindle, tailstock, Y-axis turret with live tools	<b>735SLY</b> main spindle, sub-spindle, Y-axis turret with live tools
		<b>3.15"</b> Models:	<b>835E</b> main spindle, tailstock, 1-turret	<b>835SE</b> main spindle, sub-spindle, 1-turret	<b>835LE</b> main spindle, tailstock, 1-turret with live tools	<b>835SLE</b> main spindle, sub-spindle, 1-turret with live tools	<b>835LY</b> main spindle, tailstock, Y-axis turret with live tools

### Trofeo Dual Turret Series

<b>1 3/4"</b> Models:	<b>B446S</b> main spindle, sub-spindle, 2-turrets	<b>B446SL</b> main spindle, sub-spindle, with live tools on upper or lower turret	<b>B446SLL</b> main spindle, sub-spindle, with live tools on both turrets	<b>B446SLLY</b> main and sub-spindles, Y-axis upper turret, live tools both turrets	<b>B446SY2</b> main and sub-spindles, Y-axis upper turret, Y-axis lower turret, live tools both turrets	
	<b>2 5/8"</b> Models:	<b>B465S</b> main spindle, sub-spindle, 2-turrets	<b>B465SL</b> main spindle, sub-spindle, with live tools on upper or lower turret	<b>B465SLL</b> main spindle, sub-spindle, with live tools on both turrets	<b>B465SLLY</b> main and sub-spindles, Y-axis upper turret, live tools both turrets	<b>B465SY2</b> main and sub-spindles, Y-axis upper turret, Y-axis lower turret, live tools both turrets
		<b>3.15"</b> Models:	<b>B481S</b> main spindle, sub-spindle, 2-turrets	<b>B481SL</b> main spindle, sub-spindle, with live tools on upper or lower turret	<b>B481SLL</b> main spindle, sub-spindle, with live tools on both turrets	<b>B481SLLY</b> main and sub-spindles, Y-axis upper turret, live tools both turrets

### Rapido Dual Turret

**1.42" Models:**



**B4365Y2**  
36mm bar capacity, two-turrets, two Y-axes, SuperShift sub-spindle that can super-impose on either upper or lower turret, 8,000 RPM main and sub-spindles.

Specifications contained herein are approximate and subject to change without notice.

### Multipla Triple Turret Series

<b>1 3/4", 2 5/8" and 3.15"</b> Models:	<b>B446-T3-Y3</b> main spindle, (3) Y-axis turrets, sub-spindle, C-axis, live tools on all 3 turrets, & 2.00" bar cap.	<b>B465-T3-Y3</b> main spindle, (3) Y-axis turrets, sub-spindle, C-axis, live tools on all 3 turrets, & 2.75" bar cap.	<b>B481-T3-Y3</b> main spindle, (3) Y-axis turrets, sub-spindle, C-axis, live tools on all 3 turrets, & 3.15" bar cap.
--	---	---	---

### Heavy Duty Machining

<b>3.15", 3.66", and 4.02"</b> Models:	<b>B658</b> main spindle, tailstock, 1-turret	<b>B658L</b> main spindle, tailstock, 1-turret, live tools, C-axis	<b>B658LY</b> main spindle, tailstock, Y-axis turret, live tools, C-axis	<b>B658SLY</b> main spindle, sub-spindle, Y-axis turret, live tools, C-axis
	<b>B1200L</b> main spindle, tailstock, 1-turret, live tools, C-axis	<b>B1200LY</b> main spindle, tailstock, Y-axis turret, live tools, C-axis	<b>B1200SLY</b> main spindle, sub-spindle, Y-axis turret, live tools, C-axis	<b>B1200 Barrel</b> special machine designed for accurate long barrel machining
	<b>B1700</b> main spindle, tailstock, 1-turret	<b>B1700L</b> main spindle, tailstock, 1-turret, live tools, C-axis	<b>B1700LY</b> main spindle, tailstock, Y-axis turret, live tools, C-axis	

### Y/B Axis with Automatic Tool Change

Up to 4.02" Bar Capacity / 15" Chuck Models:

<b>SmartTurn 1200L</b> variable B-axis, main spindle with Y-axis turret travel, 40 tool magazine, tailstock, and up to 4.02" bar and 14" chuck	<b>SmartTurn 1200S</b> variable B-axis, main spindle with Y-axis turret travel, sub-spindle, 40 tool magazine, tailstock, and up to 4.02" bar and 14" chuck
---	--

### Eurotech Delivers The Highest R.O.I.!



**With \$50,000 to \$100,000 of Unique Standard Features, You are Investing in a Complete EUROTECH System not just a machine.**

*"It's out of the box automation, simple and easy to use! We run it 24/7; the quality is top-notch!"*

**Kadon Precision**

STRYKER - SMITH NEPHEW - TIMKEN - HONEYWELL - WESTINGHOUSE - TYCO - TEXTRON - GOODRICH AEROSPACE - FESTO - GATES - PITNEY BOWES - G.E.

Designed with all the Automation Required for Unmanned Operation - Over 10,000 Systems Worldwide.

View machining demos at [www.EurotechElite.com](http://www.EurotechElite.com) **Runs Faster, Sleeps Less!**



**EUROTECH**  
1150 Ponce de Leon Blvd.  
Brooksville, Florida 34601

tele: 352.799.5223  
fax: 352.799.4662  
email: [sales@eurotechelite.com](mailto:sales@eurotechelite.com)  
web: [www.eurotechelite.com](http://www.eurotechelite.com)

# SMART TURN

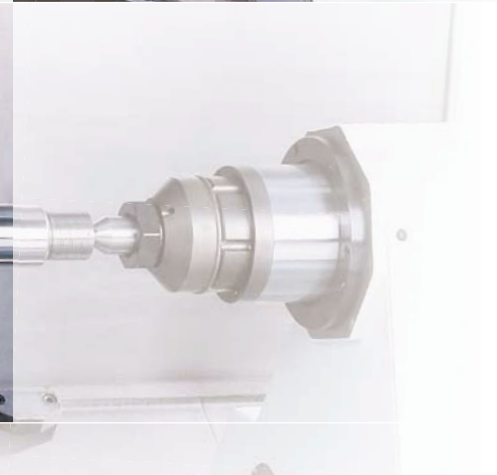
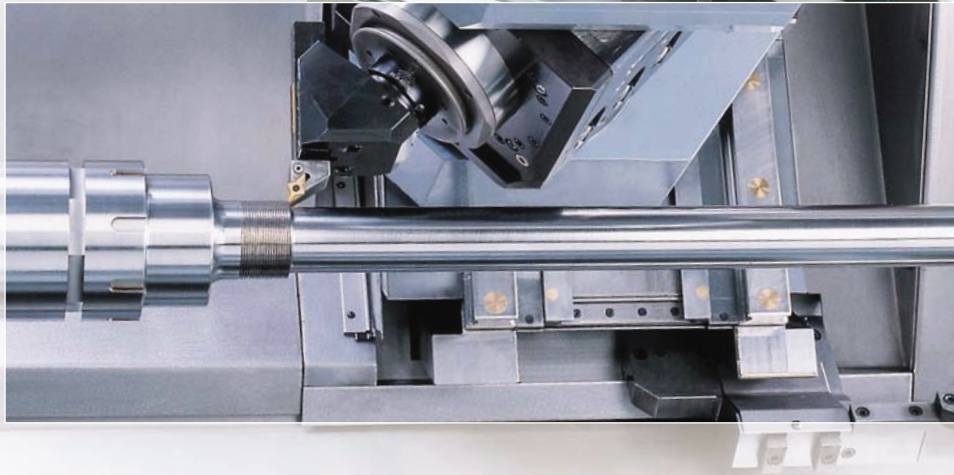
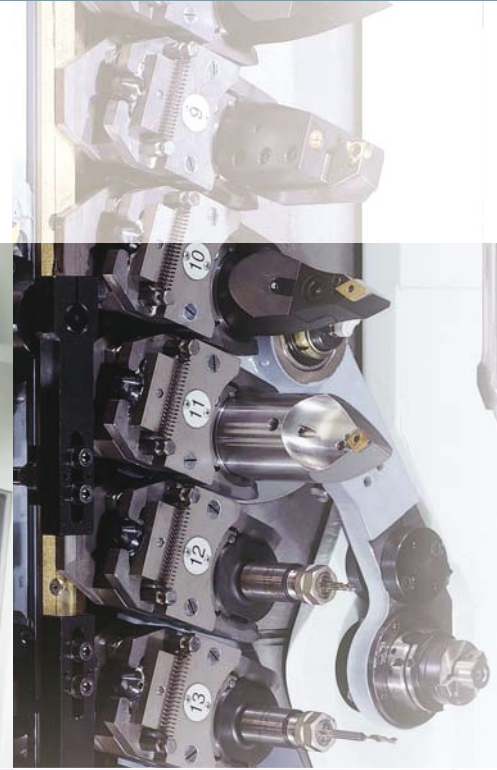

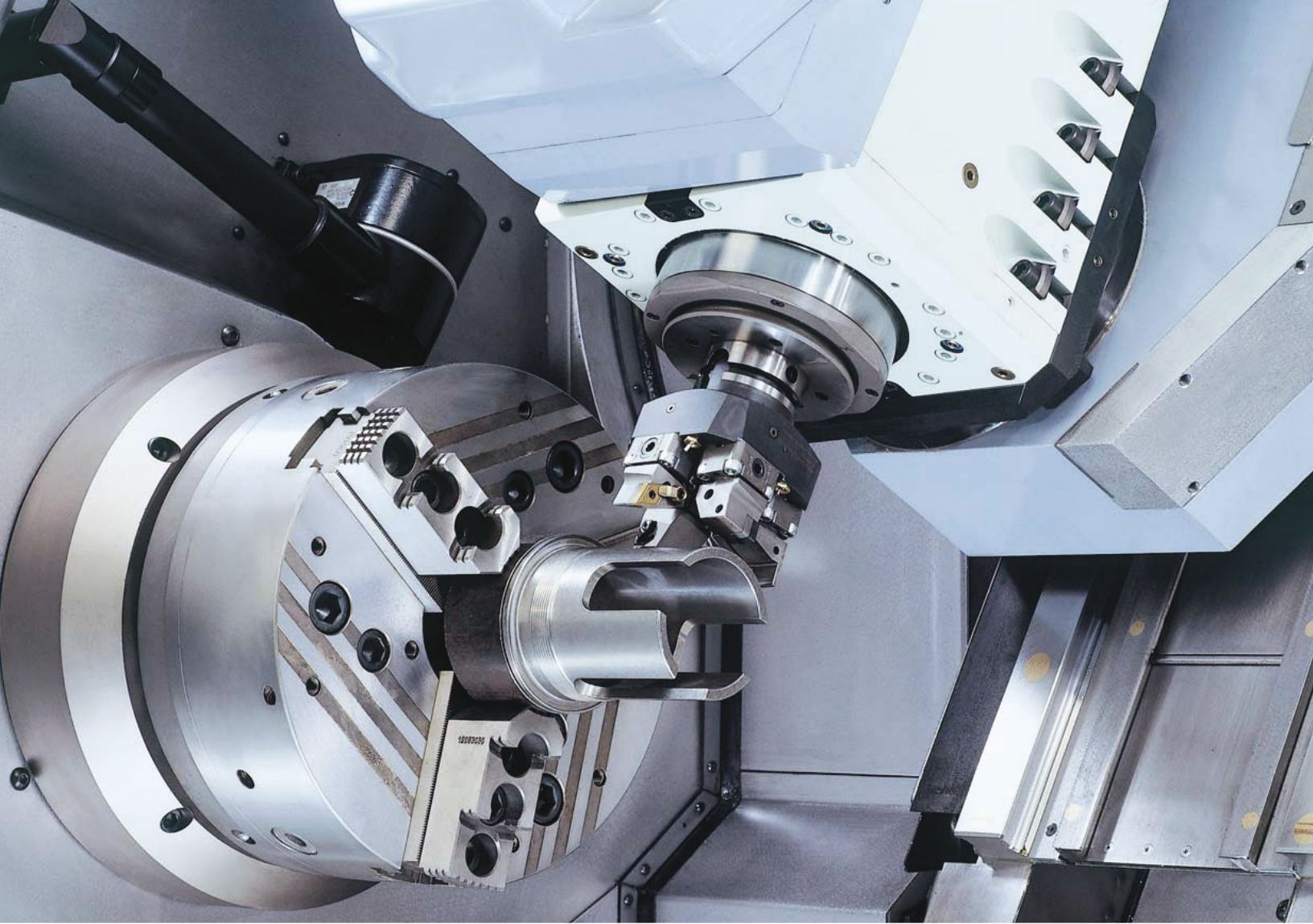

Integrated turn-mill technology.

# SMART TURN





## Multipurpose innovating technology.

The new family of multipurpose turn-mill centers SMART TURN with automatic tool change developed by EUROTECH represents the complete combination between a lathe and a machining center.

The SMART TURN is the flexible answer to ever growing demand for the production of small and medium-sized components in

various fields such as aeronautics, aerospace, medical, automotive and energy as well as the general mechanics.

SMART TURN is available in two versions: the standard model equipped with automatic tailstock and the "S" configuration equipped with sub-spindle.

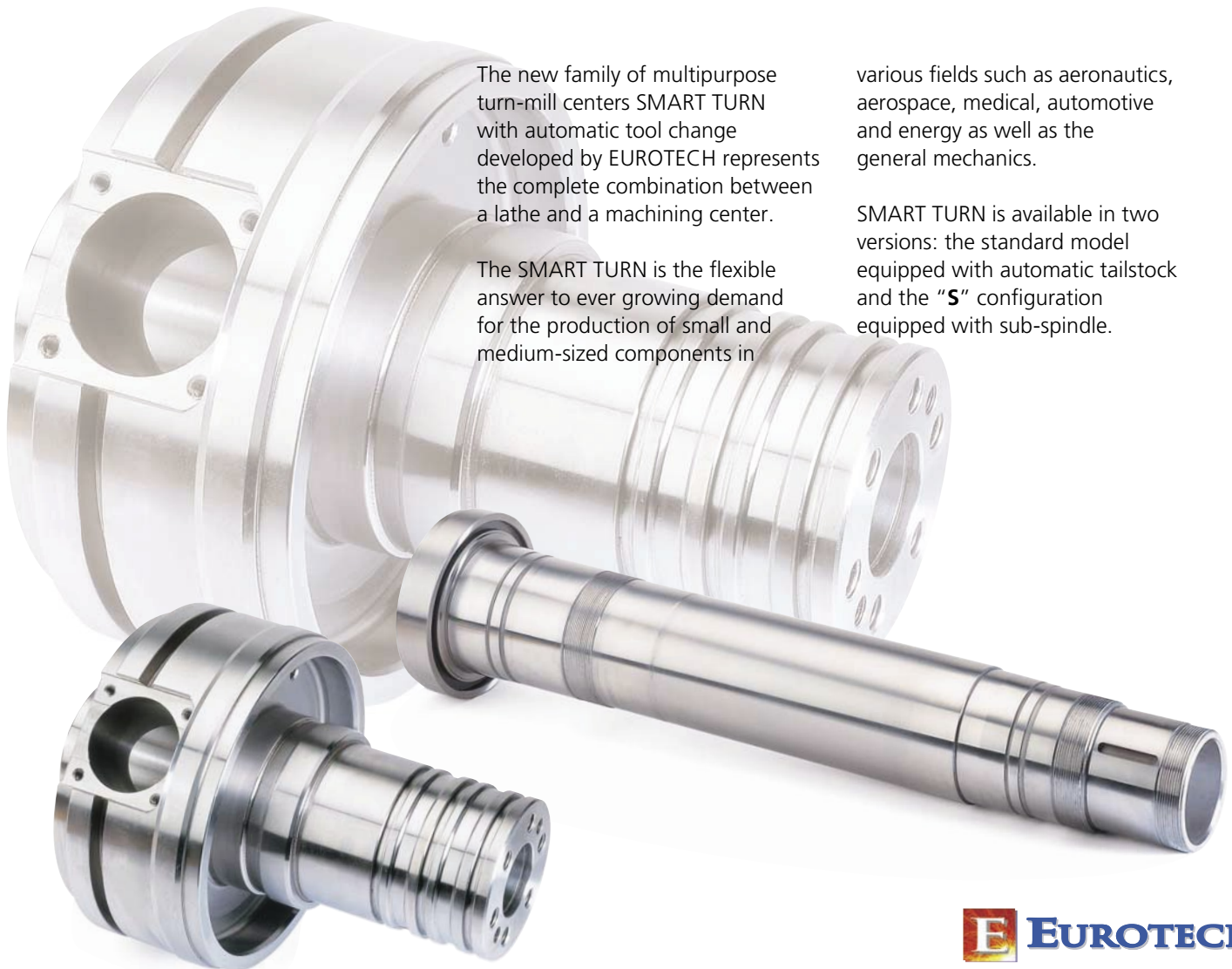

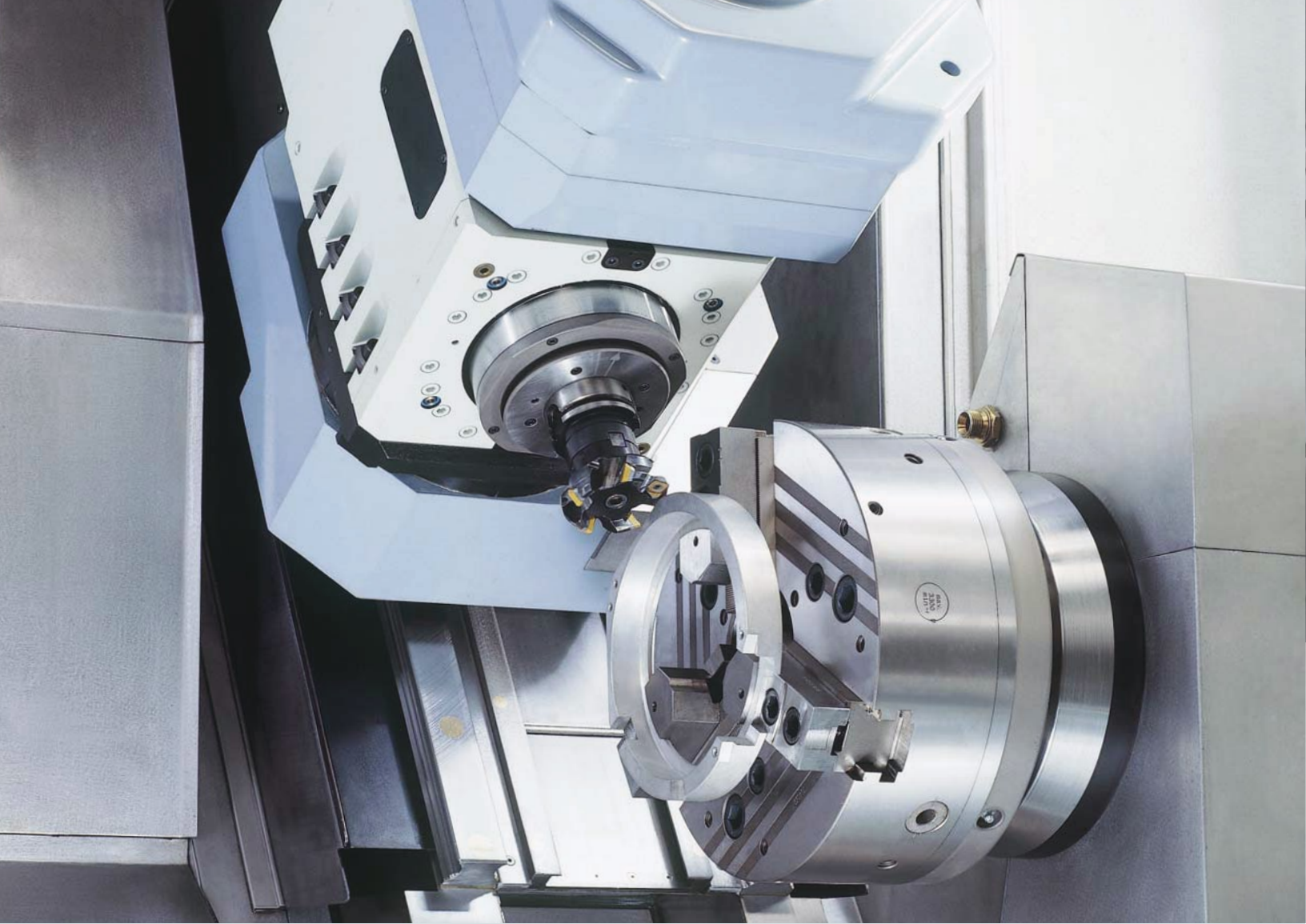

Great integrated turn-mill performance even on the sub-spindle.

# SMART TURN S





## MAIN SPECIFICATIONS

- Sturdy cast-iron machine bed with hardened and ground box-type guideways to assure top rigidity and vibration damping
- Powerful spindle motor (35 HP) to allow the optimum chip removal at any machining conditions
- Large bar capacity: 3.7 and 4.02 in

- Integrated turn/mill module fitted on the B-axis, with 210° rotation range ( $\pm 105^\circ$ )
- Locking into machining position by HIRTH-couplings of both B-axis unit (each 5°) and spindle unit each 7.5° for turning. The strong built-in synchronous spindle motor provides excellent performance in the machining of hard materials such as steel, of light alloys and aluminium
- Y-axis with 8.27 in rotation
- Powerful sub-spindle (35 HP) for complete machining of the component
- Glass scales on the X- and Y-axes.

## STANDARD EQUIPMENT

- Main spindle with large spindle bore
- Motor-driven unit on B-axis with coolant through the spindle and PEL system to monitor tool engagement
- 40 tool magazine
- Automatic tool setting arm
- HSK-63 (ICTM) tooling package for turning
- Swarf conveyor with coolant tank
- Coolant unit with low and high pressure (25 bar)
- Coolant filter
- Air conditioning for electrical cabinet, hydraulic unit and built-in motor spindles
- FANUC Manual Guide.

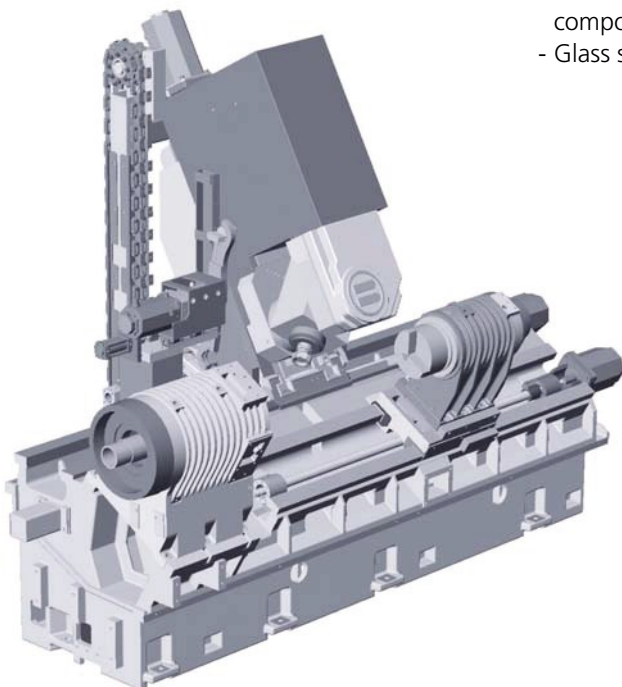

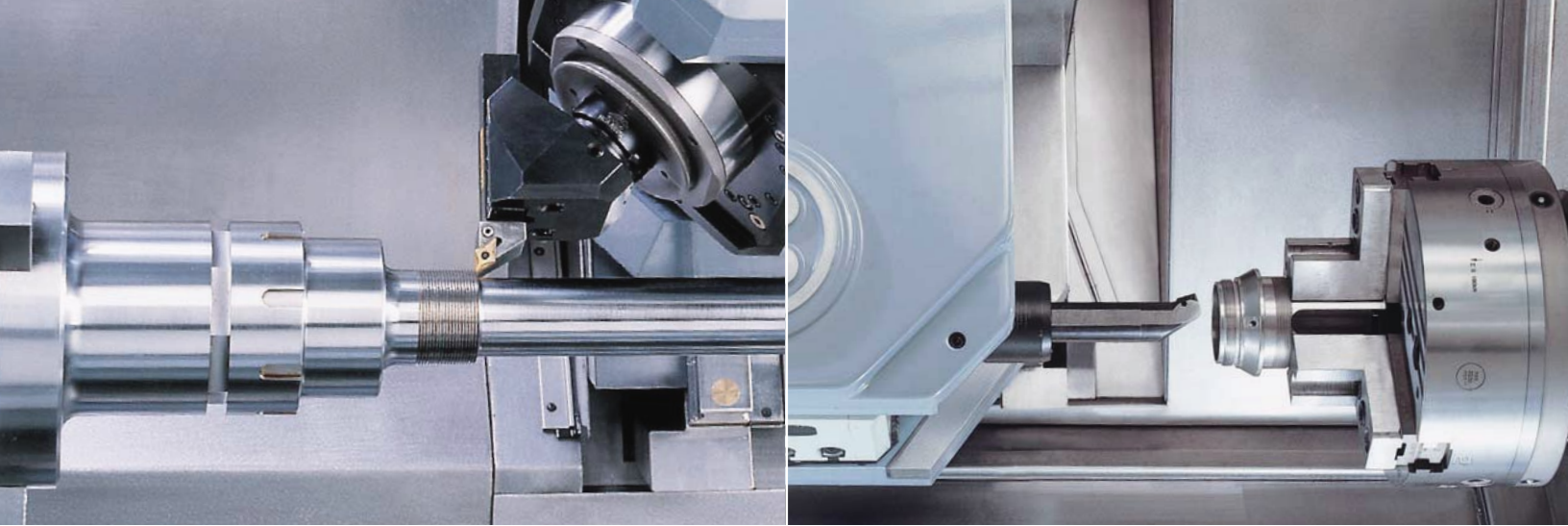

**P O W E R - T O R Q U E   D I A G R A M**

### Chip removal

The two spindles and the turn/mill unit are operated by powerful motors with great power and torque available from low rpm enabling the machining of even the hardest materials.

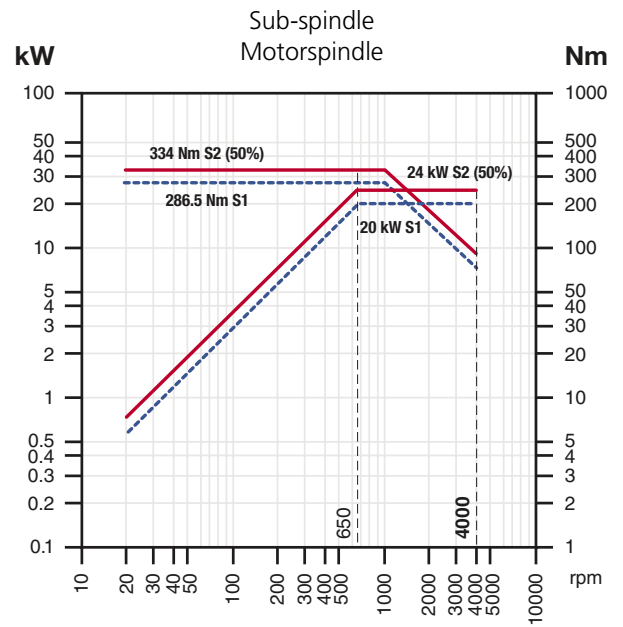
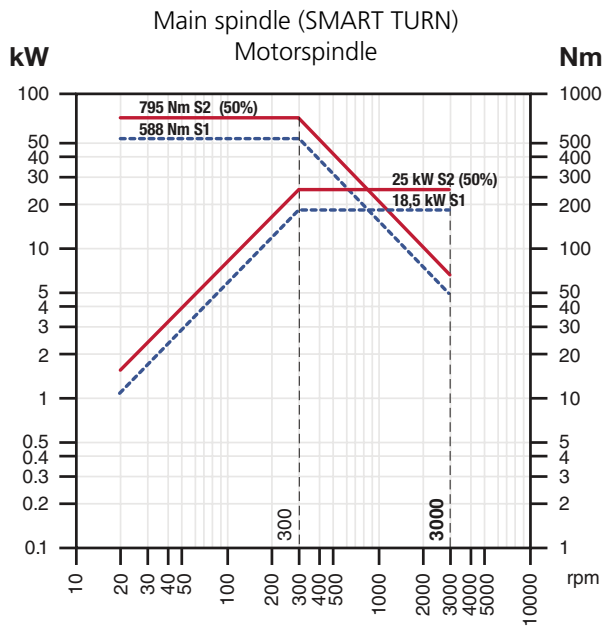
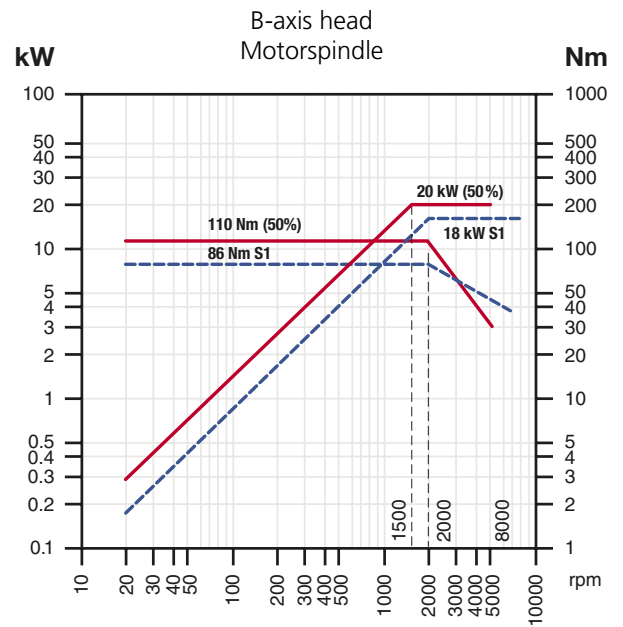

# SMART TURN

## Machining capability - Material C40

TURNING					
O.D. TURNING			DRILLING		
Spindle speed	rpm	<b>400</b>	Insert drill dia.	mm	<b>60</b>
Cutting depth	mm	<b>7</b>	Spindle speed	rpm	<b>640</b>
Cutting speed	m/min	<b>200</b>	Cutting speed	m/min	<b>120</b>
Feed rate	mm/min	<b>0,4</b>	Feed rate	mm/min	<b>0,2</b>
Volume of swarf removal	cm <sup>3</sup> /min	<b>560</b>	Volume of swarf removal	cm <sup>3</sup> /min	<b>360</b>
MACHINING WITH ROTARY TOOL					
MILLING			DRILLING		
Face mill dia.	mm	<b>63</b>	Insert drill dia.	mm	<b>40</b>
No. of 45° inserts	N°	<b>5</b>	Spindle speed	rpm	<b>1000</b>
Spindle speed	rpm	<b>800</b>	Cutting speed	m/min	<b>130</b>
Axial cutting depth	mm	<b>5</b>	Feed rate	mm/min	<b>0,14</b>
Radial cutting depth	mm	<b>60</b>	Volume of swarf removal	cm <sup>3</sup> /min	<b>180</b>
Cutting speed	m/min	<b>160</b>			
Feed rate	mm/min	<b>600</b>			
Volume of swarf removal	cm <sup>3</sup> /min	<b>180</b>			

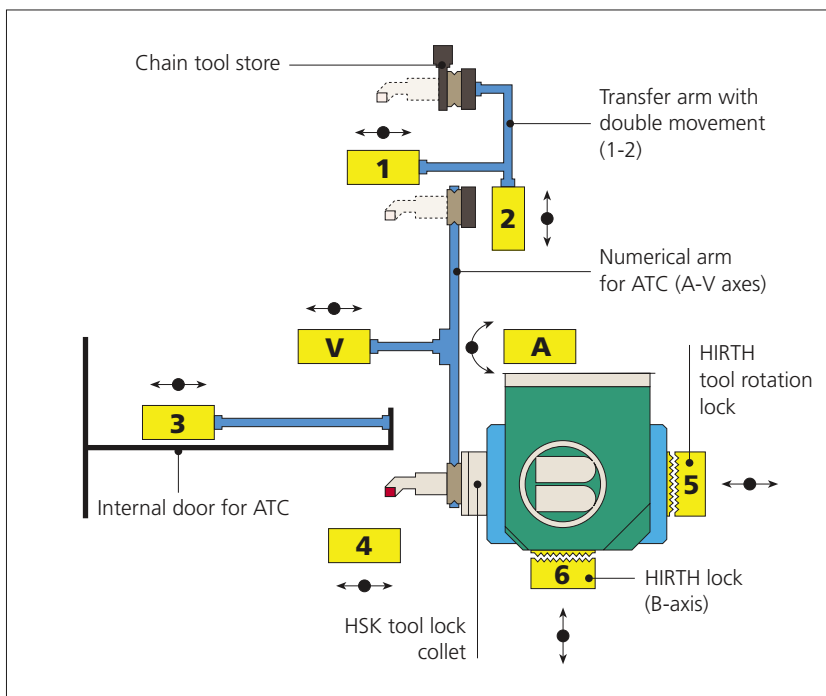
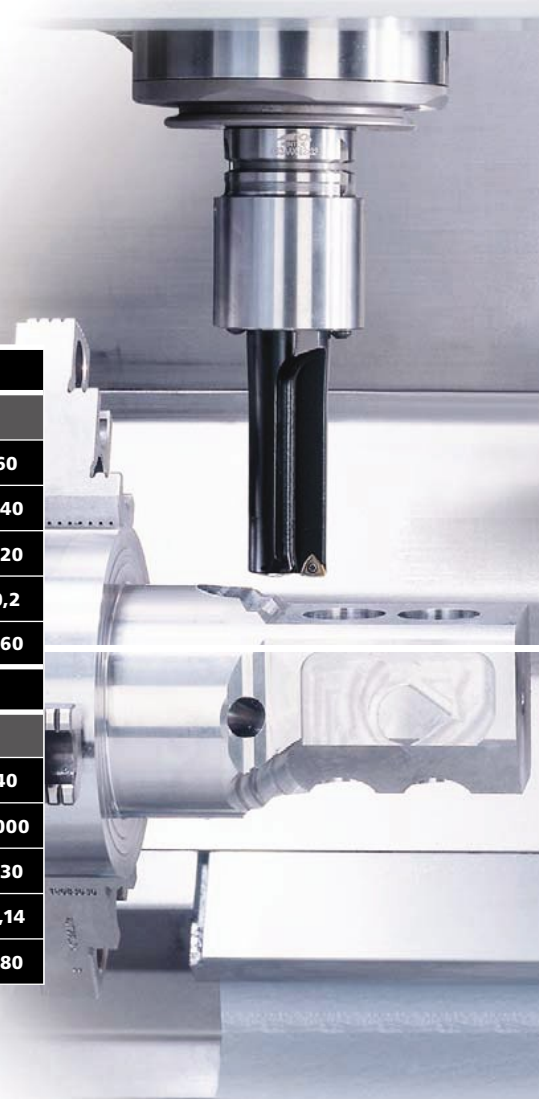

## Tool change

The servo-operated tool changer changes the tool in just 2 seconds, delivering a 5 second chip-to-chip time. The 40 tool store can accept tools up to 11.6 in long and 15.4 lbs in weight.

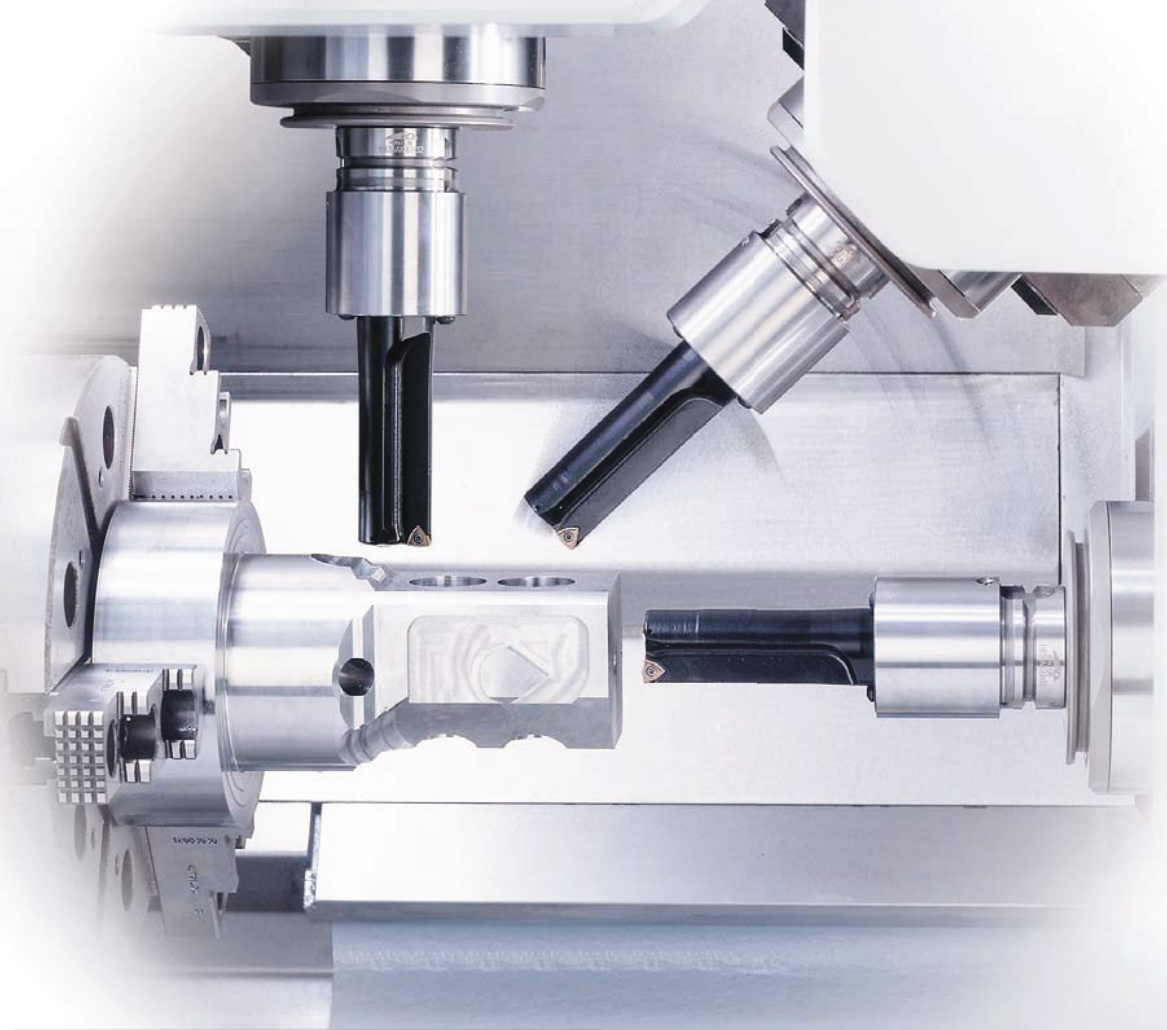

The turn-mill driven unit featuring B and Y axes allows superb chip removal, an automatic tool change system combined with a 40 tool store ensures maximum flexibility in complete machining of complex parts. Inclined turning, milling, boring and tapping operations are now possible thanks to the integrated SMART TURN turn-mill machining centres.

Versatility in

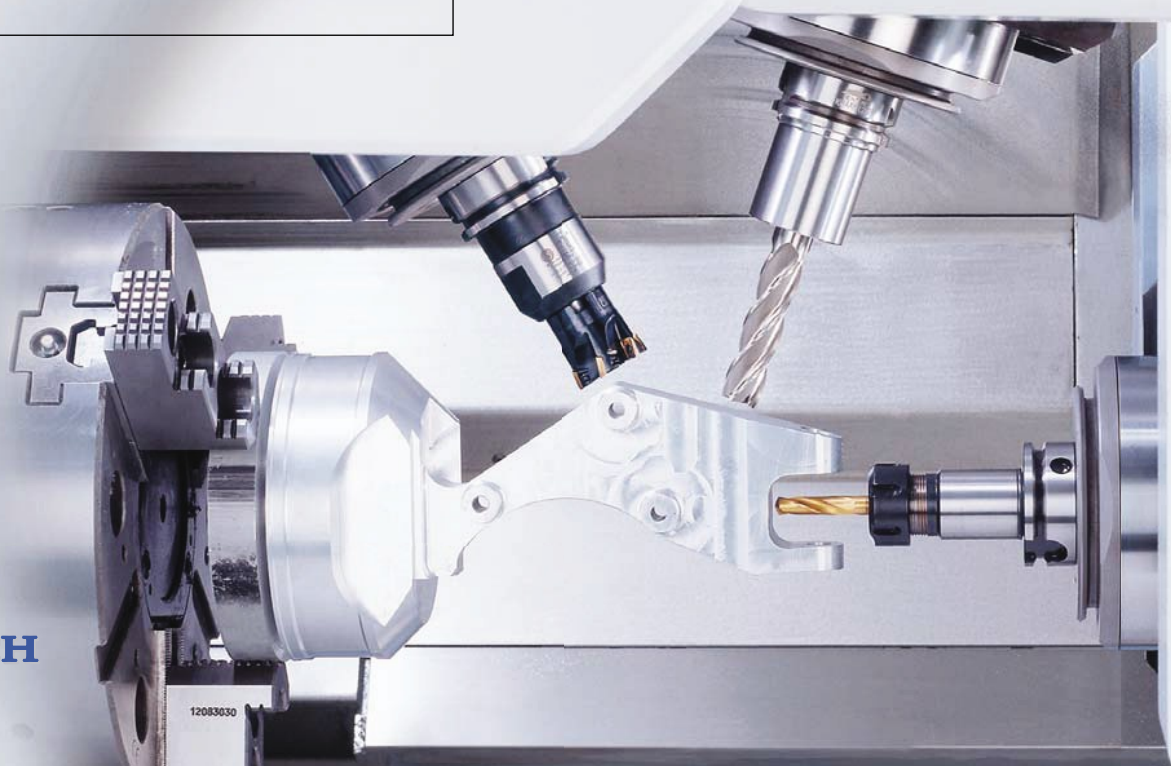

The SMART TURN "S" configuration is equipped with a powerful sub-spindle (35 HP) and torque (247 ft/lbs) to allow complete machining of the component.

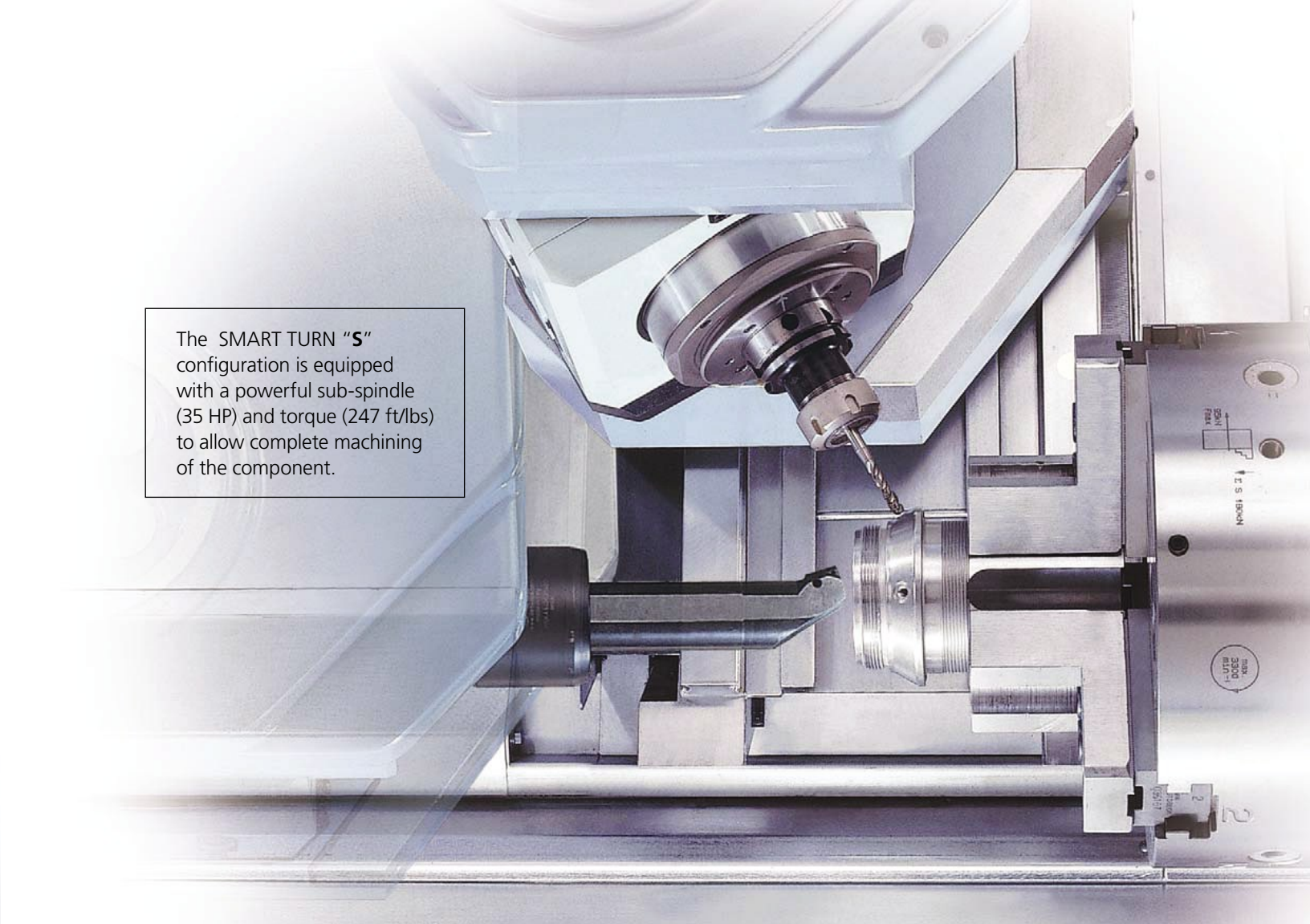

production... even on the sub-spindle.

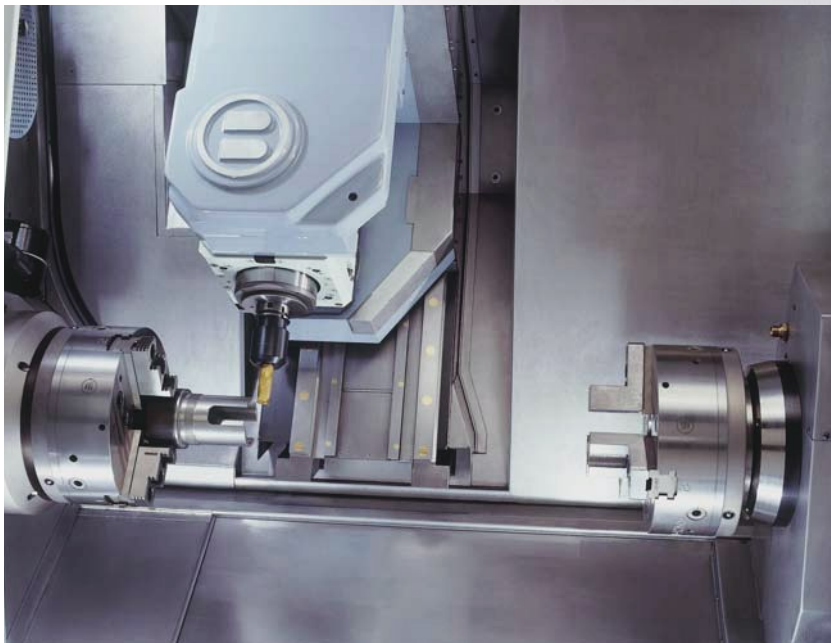



The best solutions for an integrated process.



**AUTOMATIC TAILSTOCK  
(only on the standard model)**

The programmable tailstock is automatically positioned by the Z-axis slide.

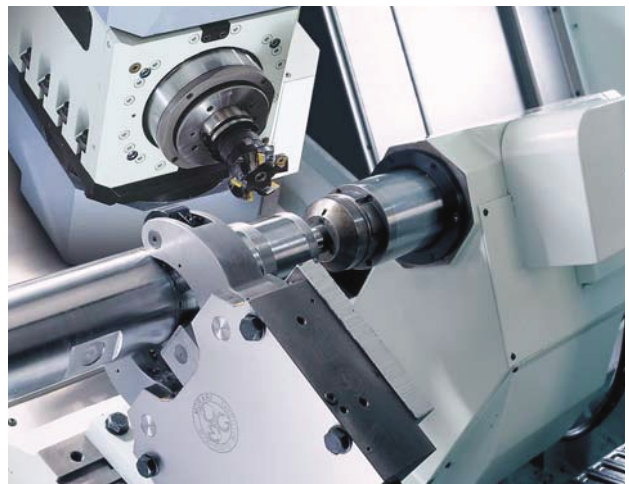

**AUTOMATIC STEADY-REST  
(optional on the standard model)**

The self-centering steady-rest is suitable to hold shafts up to 9.54 in. dia. Positioning, locking and unlocking are programmable. Available in two versions: "in cycle" steady-rest with positioning by the Z-axis slide and "travelling" steady-rest" operated by the axis motor. The movement can be either synchronized or independent from Z-axis.

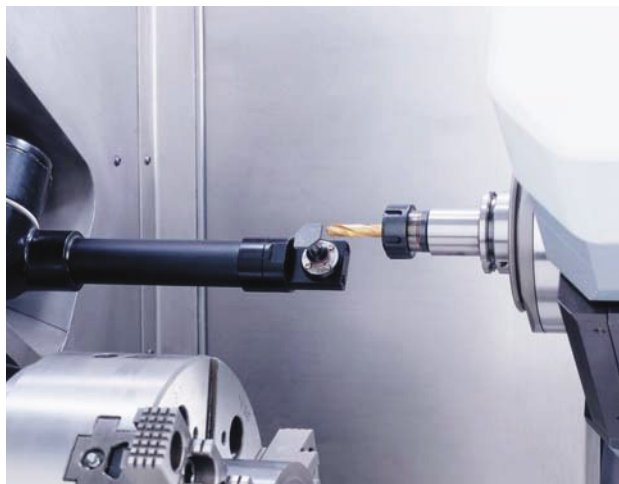
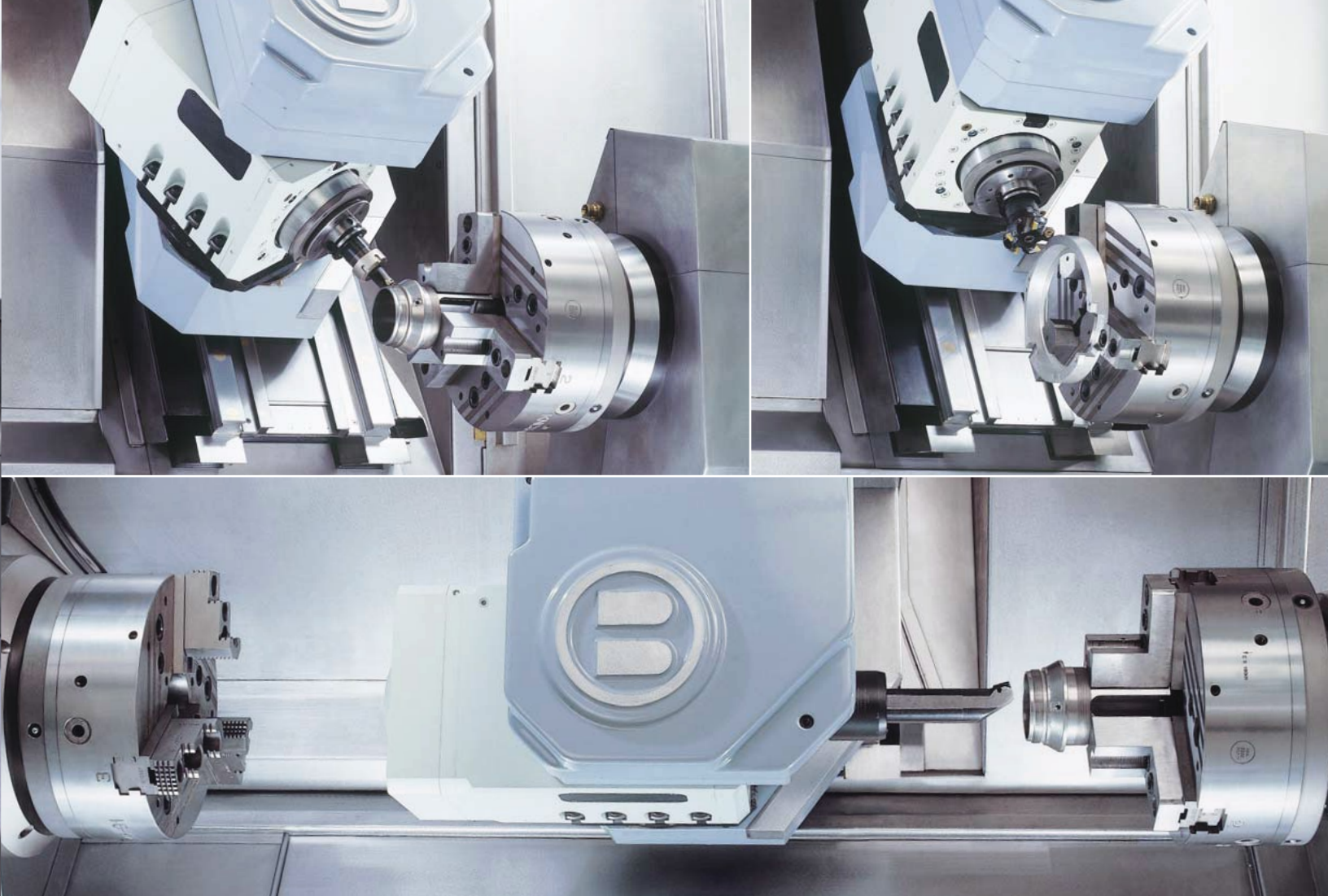

**TOOL-SETTER (standard)**

This device allows the automatic offsetting of tools. The tool tip is brought into contact with the probe and the tool offset value is automatically stored into relevant table of the CNC control.



**BAR WORK KIT (optional)**

The automatic parts-catcher combined with the pneumatic ejector on the sub-spindle allows the unloading of the finished part during bar machining.

# SMART TURN

T O O L I N G S Y S T E M

**The turn/mill unit is equipped with HSK-A63 attachment.**

The turning toolholders require the standard HSK-A63 ICTM attachment, which assures maximum engagement accuracy.

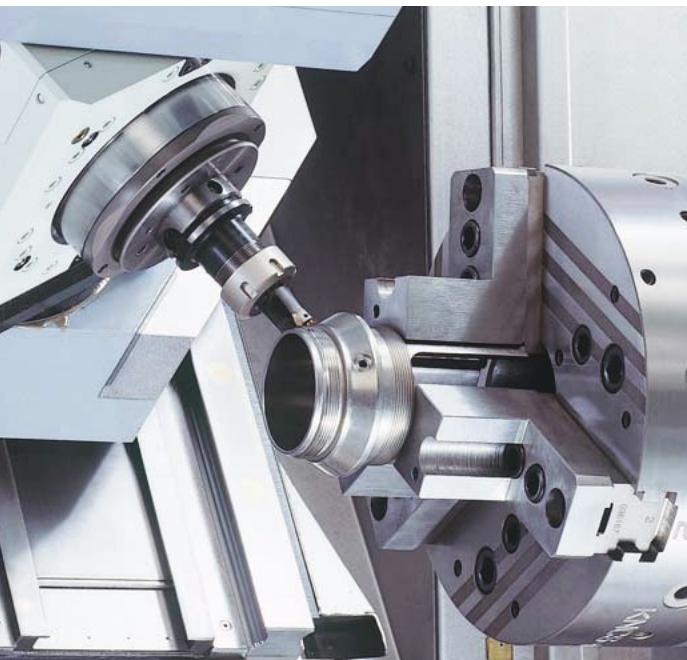
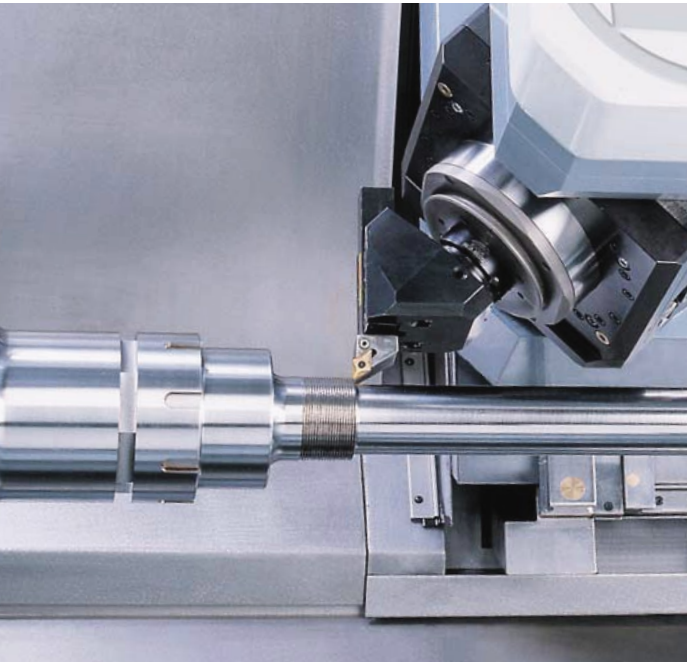
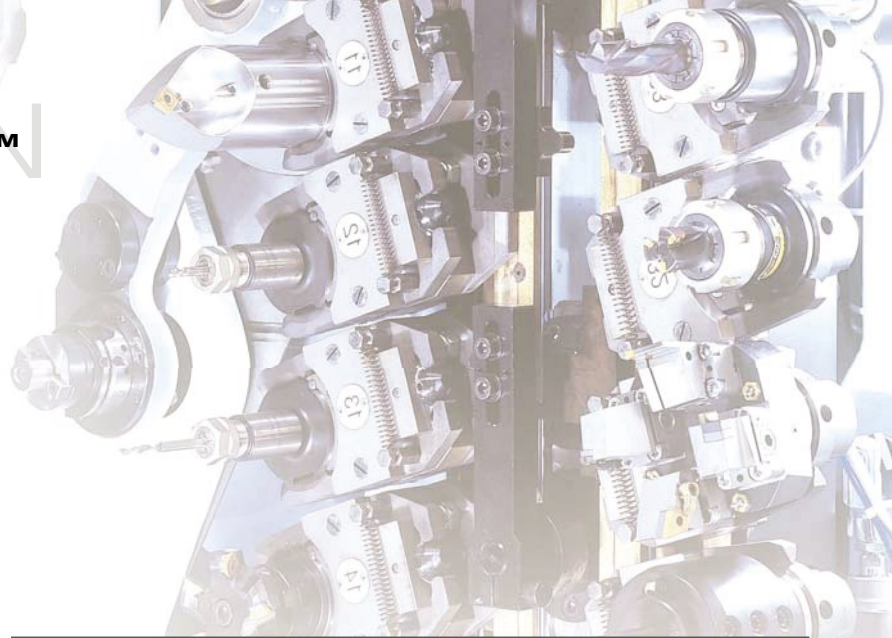

## T U R N I N G T O O L H O L D E R S



I.D. turning



I.D. turning



O.D. turning



Cut-off

## M I L L I N G / D R I L L I N G T O O L H O L D E R S



Collet holder ER 25-32-40



Bit holder WELDON



Insert bit holder



Face combined cutter holder

SMART TURN S

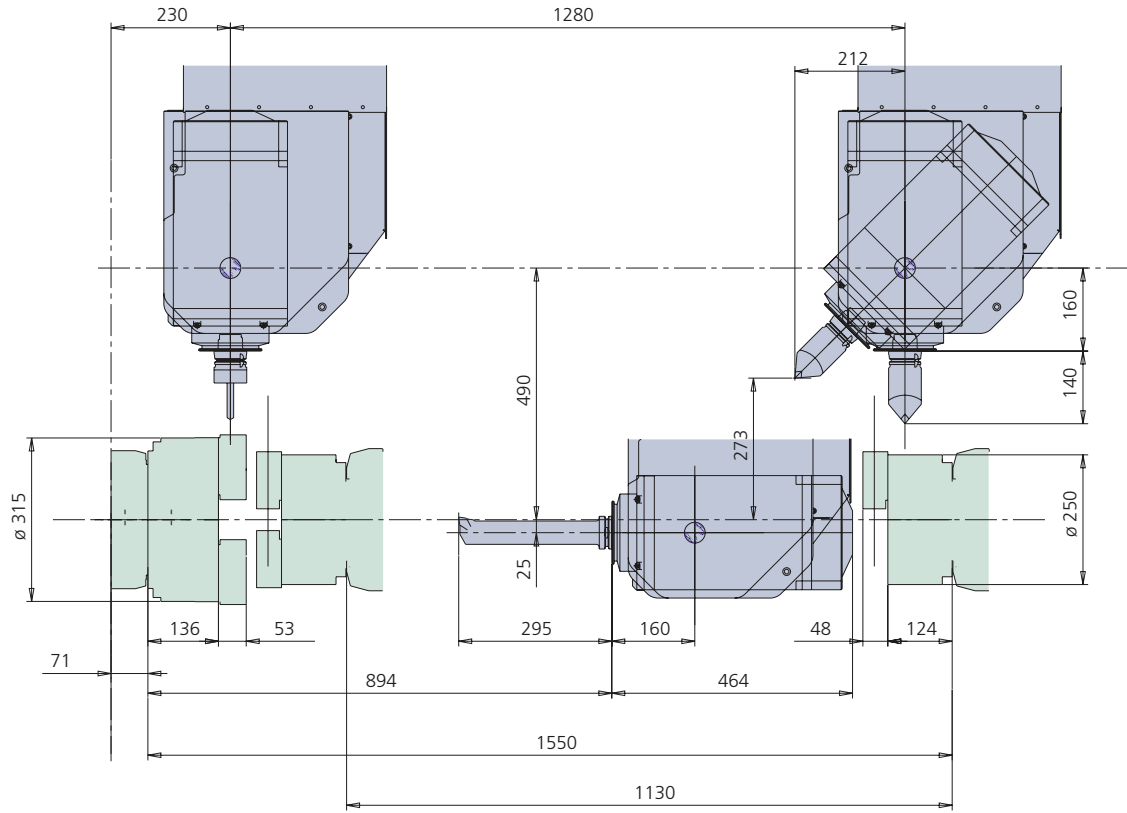

SMART TURN

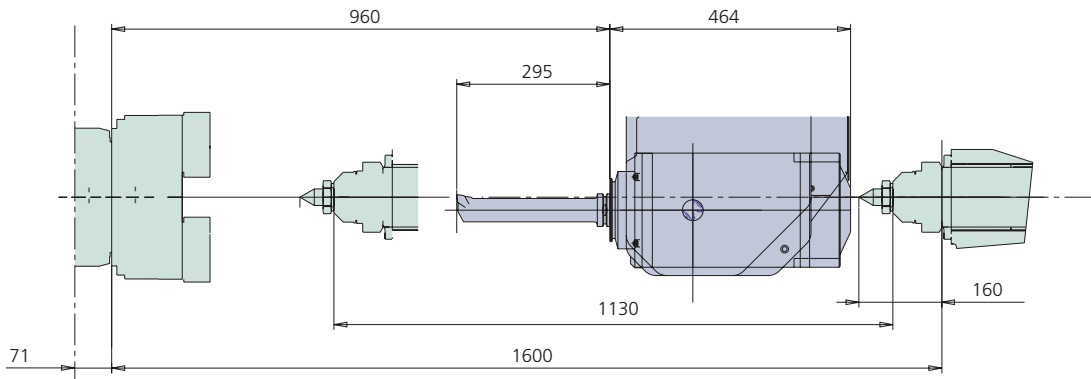

TURN/MILL MODULE - B AXIS FIELD

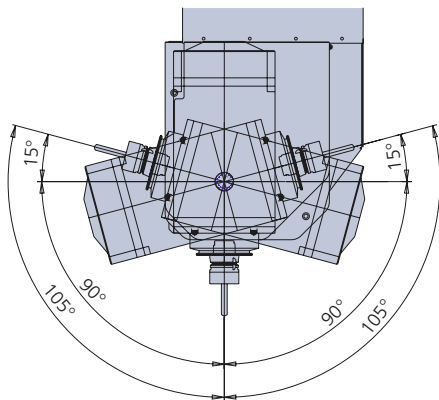

TURN/MILL MODULE - Y AXIS FIELD

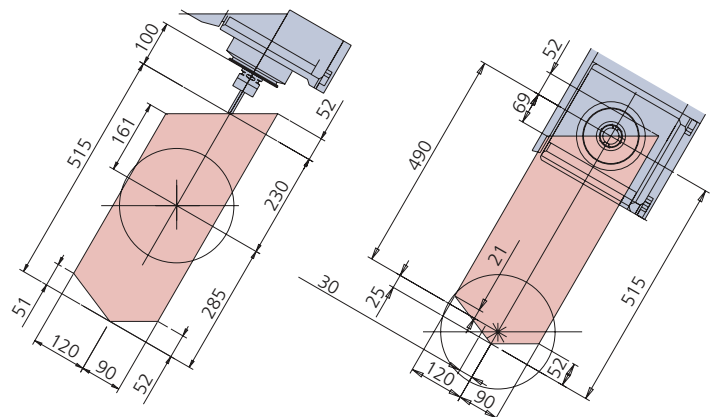



# Automated process.



## MANUAL GUIDE: QUICK AND EASY FOR PROGRAM RELIABILITY

The innovative MANUAL GUIDE software package provides operators with access to a very simple and user-friendly graphics interface, strong "editing" functions and offers a wide selection of machining cycles (turning, milling and drilling). This system allows the execution of even the most complex programs with ease of operation. The 3D simulation facilitates the checking of programmes before machining operations.

## CNC UNIT

- CNC unit mod. Fanuc 31i-T:
- 10.4" colour liquid crystal display
- Alphanumeric full-keyboard
- BIGLIA operator panel featuring softkeys.

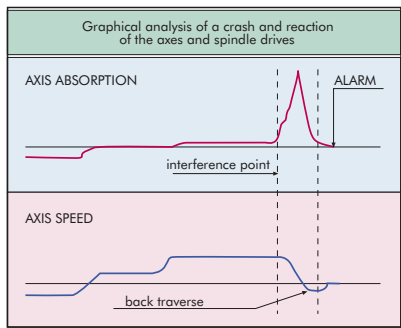

## DAMAGE PROTECTION (AIR BAG)

This special software detects the abnormal load created by a collision during rapid traverse or within the machining process. When a collision occurs, spindle rotation is stopped and the axis movement is halted thus damping the interference and limiting damage to the tooling. NOTE: this function does not prevent from collision.

## SBS: BIGLIA SAFETY SOFTWARE TOOL LOAD MONITORING

This system monitors the loading of the most heavily used tools: e.g. 1st op. cutting tools, roughening tools, drills or U-drills. It ensures safe automatic machining with limited operator presence (option).



T E C H N I C A L   S P E C I F I C A T I O N S

		SMART TURN	SMART TURN S
<b>MACHINING FIELD</b>			
Max. rotation diameter	in	29.5	29.5
Max. turning diameter	in	19.7	19.7
Max. turning length std / opt	in	47 / 64	47 / 64
<b>LINEAR AXES</b>			
X-axis travel	in	20.2	20.2
Z-axis travel	in	50.4	50.4
Y-axis travel	in	8.27 (+4.72 / -3.55)	8.27 (+4.72 / -3.55)
<b>B-AXIS</b>			
Rotation field	deg	210° (±105°)	210° (±105°)
Angular positioning	deg	0,001°	0,001°
<b>MAIN SPINDLE</b>			
Max. speed rotation	rpm	3000	3000
Spindle nose - DIN 55026	ASA	8"	8"
Max. bar capacity (opt.)	in	3.7 / (102*)	3.7 / (102*)
Motor power	HP	35	35
Max. torque	ft.lb	587	587
Chuck diameter	in	15"	15"
<b>B-AXIS TURN/MILL UNIT</b>			
Tool		HSK-A63	HSK-A63
Max. rotation speed (opt.)	rpm	8000	8000
Max. motor power	HP	27	27
Max. torque	ft.lb	83	83
<b>TOOL MAGAZINE</b>			
Number of tools	N°	40	40
<b>SUB-SPINDLE</b>			
Max. rotation speed	rpm	-	4000
Spindle nose - DIN 55026	ASA	-	6"
Max. bar capacity (opt.)	in	-	2.65
Max. motor power	HP	-	35
Max. torque	ft.lb	-	247
W-axis travel	in	-	44.7
Chuck diameter	in	-	10"
<b>MACHINE INSTALLATION DATA</b>			
Layout (L x B x H)	in	217x91x95	217x91x95
Machine weight	lb	18,100	18,500

\* with belt-type transmission

M A C H I N E   D I M E N S I O N S

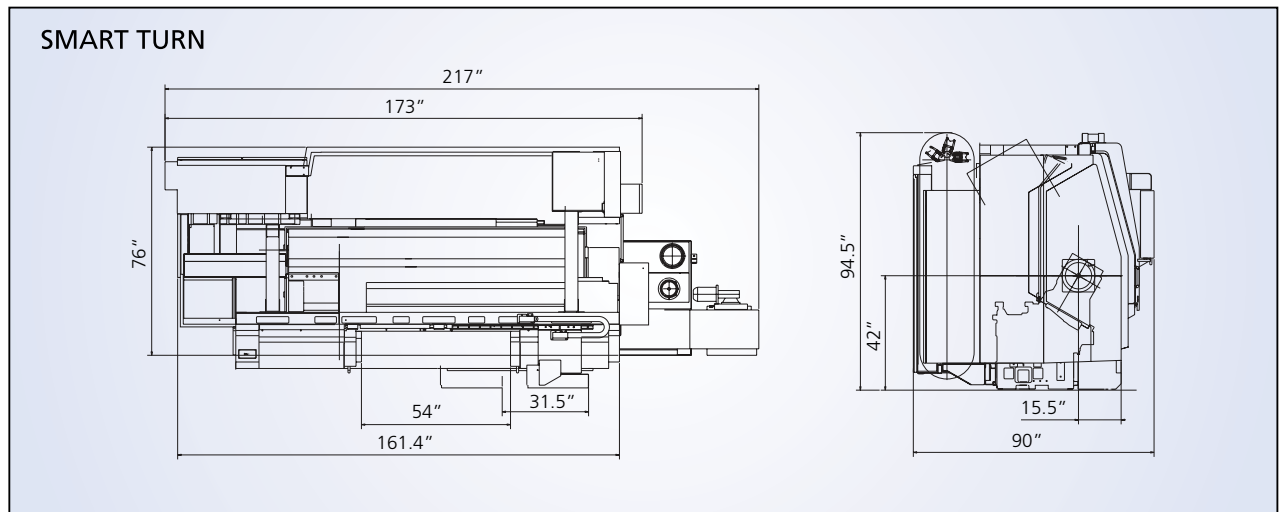

SMART TURN